

Specifications:		<u>25" Tubes</u>	<u>Express Pkg.</u>
LOA.....	23' 8"	Max. HP Capacity.....	150 hp
Pontoon Length.....	22' 6"	Approx. Hull Weight.....	1860 lbs
Deck Length.....	21' 11"	Person Capacity.....	13 / 1790 lbs
Deck Width.....	8' 6"		
Pontoon Diameter.....	25"		
Pontoon Gauge.....	.080"		

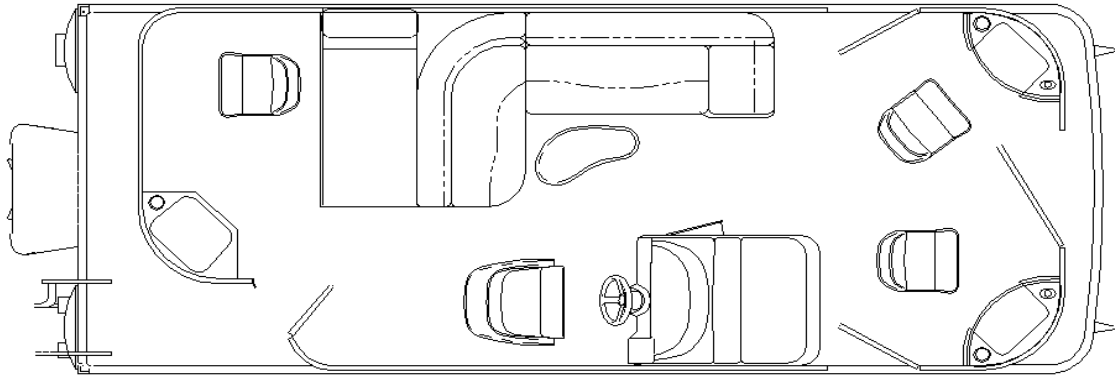

Standard Features

24 Gallon Transom Fuel Tank
 25" Pontoons
 3 Fishing Seats
4 Pole Rod Holder
 6" Stainless Steel Cleats
8.5' x 10' Bimini w/Boot - Surlast
 Anodized, Raised Rails for Drainage
 Bimini Trailing Struts
 Captain's Seat w/ Slider / Swivel
 Fire Extinguisher
Full length skirting
High Performance Palm Carpet
Kidney table
Playpen Cover - Surlast
Port Bow Livewell
Rail system - Angled top rail verticals
Seat hinges powder coated Java
 Stainless Deck Bolts
 Stainless Steel Corner Castings
Stainless Steel Ring Cup holders
Starboard Bow Storage
 Stern Entry Platform & Ladder
Stern Livewell
Stern Storage Closet with optional privacy
 Underdeck Spray Deflectors
Upgraded Graphics Package in Java

Console Features:

12 Volt Receptacle (15 Amp)
Majestic Burl Dash
 Faria Gauges
One piece fiberglass fishing console
 Instrumentation Includes:
 Tach, Fuel & Trim Gauges
 Lockable Console Door
 Rocker Switches w/dash mounted breakers
 Soft Cooler
Sony GT Series CD - MP3, 4 speakers
 w/ color matched speaker grills
Tiger polished steering wheel